

# 20M Series Medium Pressure Fittings

20,000 psig (1379 bar)

Fittings
Tubing
Quick Couplings
Line Filters
Valves
Sour Service Products
Subsea Valves
Tools and Installation Instructions
Technical Information
Part Number Crossover Charts



# Contents

Glands - MG



A-15

Collars - MCO



A-15

Plugs - MTP



A-16

Caps - MTC



A-16

Unions - MU

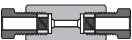

A-16

Reducing Unions - MU



A-17

Unions (Slip Type) - MSU



A-17

Bulkhead Unions - MBU

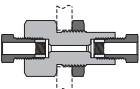

A-18

Union Elbows - MLU



A-18

Union Tees - MT

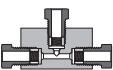

A-19

Union Crosses - MX

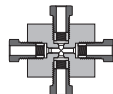

A-19

Anti-vibration Gland Assemblies - MAV

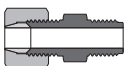

A-20

[Installation Instructions](#)

H-07

[Connection Information](#)

I-02

[Ordering Number Description](#)

A-21

Fittings

Tubing

Quick Couplings

Line Filters

Valves

Sour Service Products

Subsea Valves

Tools and Installation Instructions

Technical Information

Part Number Crossover Charts

## Features

- ⦿ Working pressure: 20,000 psig (1379 bar)
- ⦿ Working temperature range: -423°F to 1200°F (-252°C to 649°C)
- ⦿ Use with T20M series tubing as standard, tubing sizes available in 1/4", 3/8", 9/16", 3/4" and 1"
- ⦿ High tensile 316 stainless steel material
- ⦿ Every fitting marked with size, material and heat number

## Construction

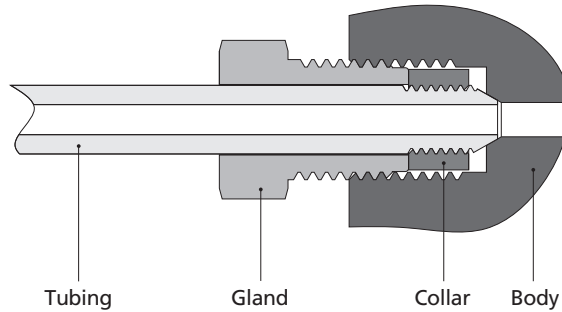

## Ordering Information and Dimensions

Dimensions are for reference only and are subject to change.

### Glands

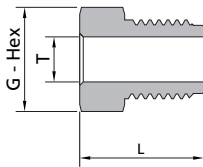

Tube			
T - Tube O.D. in.	Ordering Number	Dimensions, in. (mm)	
		G	L
1/4	SS-MG-MF4	0.50 (12.7)	0.58 (14.7)
3/8	SS-MG-MF6	0.63 (15.9)	0.73 (18.5)
9/16	SS-MG-MF9	0.94 (23.8)	0.88 (22.4)
3/4	SS-MG-MF12	1.19 (30.2)	1.00 (25.4)
1	SS-MG-MF16	1.38 (34.9)	1.38 (35.1)

### Collars

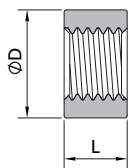

Tube			
T - Tube O.D. in.	Ordering Number	Dimensions, in. (mm)	
		D	L
1/4	SS-MCO-MF4	0.38 (9.7)	0.22 (5.6)
3/8	SS-MCO-MF6	0.47 (11.9)	0.25 (6.4)
9/16	SS-MCO-MF9	0.72 (18.3)	0.31 (7.9)
3/4	SS-MCO-MF12	0.94 (23.8)	0.37 (9.4)
1	SS-MCO-MF16	1.25 (31.8)	0.50 (12.7)

Fittings  
 Tubing  
 Quick Couplings  
 Line Filters  
 Valves  
 Sour Service Products  
 Subsea Valves  
 Tools and Installation Instructions  
 Technical Information  
 Part Number Crossover Charts

Plugs<sup>①</sup>

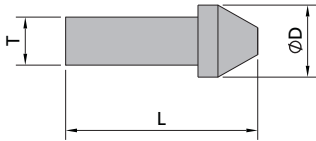

Tube			
T - Tube O.D. in.	Ordering Number	Dimensions, in. (mm)	
		D	L
1/4	SS-MTP-MF4	0.38 (9.7)	0.94 (23.8)
3/8	SS-MTP-MF6	0.47 (11.9)	1.18 (30.0)
9/16	SS-MTP-MF9	0.72 (18.3)	1.40 (35.6)
3/4	SS-MTP-MF12	0.94 (23.8)	1.69 (42.9)
1	SS-MTP-MF16	1.25 (31.8)	2.20 (55.9)

① When using plug, collar is not required.

Caps

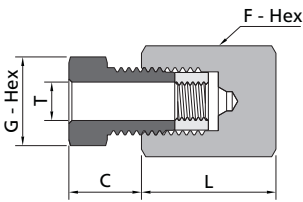

Tube					
T - Tube O.D. in.	Ordering Number	Dimensions, in. (mm)			
		L	C	G	F
1/4	SS-MTC-MF4	0.81 (20.6)	0.38 (9.7)	0.50 (12.7)	0.63 (15.9)
3/8	SS-MTC-MF6	1.13 (28.6)	0.44 (11.2)	0.63 (15.9)	0.75 (19.1)
9/16	SS-MTC-MF9	1.38 (34.9)	0.55 (14.0)	0.94 (23.8)	1.00 (25.4)
3/4	SS-MTC-MF12	1.75 (44.5)	0.60 (15.2)	1.19 (30.2)	1.38 (34.9)
1	SS-MTC-MF16	2.25 (57.2)	0.74 (18.7)	1.38 (34.9)	1.75 (44.5)

Unions

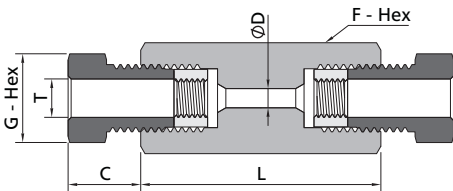

Tube						
T - Tube O.D. in.	Ordering Number	Dimensions, in. (mm)				
		L	C	D	G	F
1/4	SS-MU-MF4	1.62 (41.1)	0.38 (9.7)	0.11 (2.8)	0.50 (12.7)	0.63 (15.9)
3/8	SS-MU-MF6	1.75 (44.5)	0.44 (11.2)	0.20 (5.1)	0.63 (15.9)	0.75 (19.1)
9/16	SS-MU-MF9	2.14 (54.3)	0.55 (14.0)	0.31 (7.9)	0.94 (23.8)	1.00 (25.4)
3/4	SS-MU-MF12	2.50 (63.5)	0.60 (15.2)	0.44 (11.1)	1.19 (30.2)	1.38 (34.9)
1	SS-MU-MF16	3.50 (88.9)	0.74 (18.7)	0.56 (14.3)	1.38 (34.9)	1.75 (44.5)

Fittings
Tubing
Quick Couplings
Line Filters
Valves
Sour Service Products
Subsea Valves
Tools and Installation Instructions
Technical Information
Part Number Crossover Charts

**Reducing Unions**

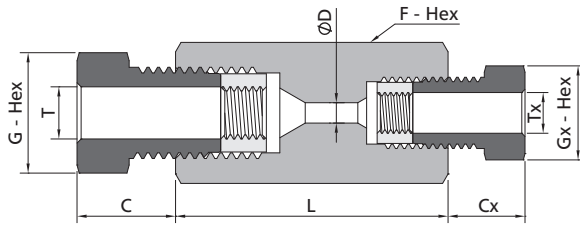

Tube			Dimensions, in. (mm)							
T - Tube O.D. in.	Tx - Tube O.D. in.	Ordering Number	L	C	Cx	D	G	Gx	F	
3/8	1/4	SS-MU-MF6-MF4	1.75 (44.5)	0.44 (11.2)	0.38 (9.7)	0.11 (2.8)	0.63 (15.9)	0.50 (12.7)	0.75 (19.1)	
9/16	1/4	SS-MU-MF9-MF4	2.00 (50.8)	0.55 (14.0)	0.38 (9.7)	0.11 (2.8)	0.94 (23.8)	0.50 (12.7)	1.00 (25.4)	
9/16	3/8	SS-MU-MF9-MF6	2.00 (50.8)	0.55 (14.0)	0.44 (11.2)	0.20 (5.1)	0.94 (23.8)	0.63 (15.9)	1.00 (25.4)	
3/4	1/4	SS-MU-MF12-MF4	2.25 (57.2)	0.60 (15.2)	0.38 (9.7)	0.11 (2.8)	1.19 (30.2)	0.50 (12.7)	1.38 (34.9)	
3/4	3/8	SS-MU-MF12-MF6	2.25 (57.2)	0.60 (15.2)	0.44 (11.2)	0.20 (5.1)	1.19 (30.2)	0.63 (15.9)	1.38 (34.9)	
3/4	9/16	SS-MU-MF12-MF9	2.50 (63.5)	0.60 (15.2)	0.55 (14.0)	0.31 (7.9)	1.19 (30.2)	0.94 (23.8)	1.38 (34.9)	
1	1/4	SS-MU-MF16-MF4	2.75 (69.9)	0.74 (18.7)	0.38 (9.7)	0.11 (2.8)	1.38 (34.9)	0.50 (12.7)	1.75 (44.5)	
1	3/8	SS-MU-MF16-MF6	2.88 (73.0)	0.74 (18.7)	0.44 (11.2)	0.20 (5.1)	1.38 (34.9)	0.63 (15.9)	1.75 (44.5)	
1	9/16	SS-MU-MF16-MF9	3.00 (76.2)	0.74 (18.7)	0.55 (14.0)	0.31 (7.9)	1.38 (34.9)	0.94 (23.8)	1.75 (44.5)	
1	3/4	SS-MU-MF16-MF12	3.00 (76.2)	0.74 (18.7)	0.60 (15.2)	0.44 (11.1)	1.38 (34.9)	1.19 (30.2)	1.75 (44.5)	

**Unions (Slip Type)**

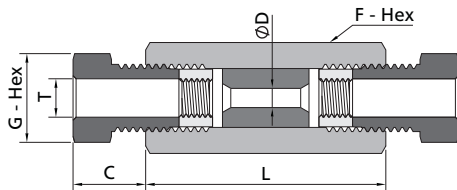

Tube		Dimensions, in. (mm)				
T - Tube O.D. in.	Ordering Number	L	C	D	G	F
1/4	SS-MSU-MF4	1.62 (41.1)	0.38 (9.7)	0.11 (2.8)	0.50 (12.7)	0.63 (15.9)
3/8	SS-MSU-MF6	1.75 (44.5)	0.44 (11.2)	0.20 (5.1)	0.63 (15.9)	0.75 (19.1)
9/16	SS-MSU-MF9	2.14 (54.3)	0.55 (14.0)	0.31 (7.9)	0.94 (23.8)	1.00 (25.4)
3/4	SS-MSU-MF12	2.50 (63.5)	0.60 (15.2)	0.44 (11.1)	1.19 (30.2)	1.38 (34.9)
1	SS-MSU-MF16	3.50 (88.9)	0.74 (18.7)	0.56 (14.3)	1.38 (34.9)	1.75 (44.5)

Fittings  
 Tubing  
 Quick Couplings  
 Line Filters  
 Valves  
 Sour Service Products  
 Subsea Valves  
 Tools and Installation Instructions  
 Technical Information  
 Part Number Crossover Charts

**Bulkhead Unions**

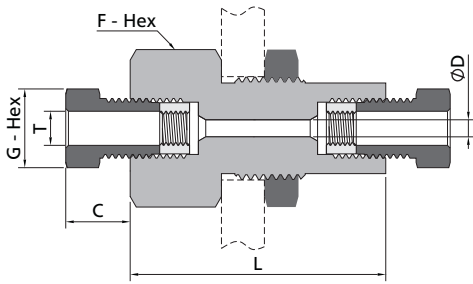

Tube		Dimensions, in. (mm)						
T - Tube O.D. in.	Ordering Number	L	C	D	G	F	Panel Hole Size	Max. Panel Thickness
1/4	SS-MBU-MF4	1.88 (47.8)	0.38 (9.7)	0.11 (2.8)	0.50 (12.7)	1.00 (25.4)	0.81 (20.6)	0.38 (9.7)
3/8	SS-MBU-MF6	2.00 (50.8)	0.44 (11.2)	0.20 (5.1)	0.63 (15.9)	1.06 (27.0)	0.94 (23.9)	0.38 (9.7)
9/16	SS-MBU-MF9	2.38 (60.5)	0.55 (14.0)	0.31 (7.9)	0.94 (23.8)	1.38 (34.9)	1.13 (28.6)	0.38 (9.7)
3/4	SS-MBU-MF12	2.62 (66.5)	0.60 (15.2)	0.44 (11.1)	1.19 (30.2)	1.88 (47.6)	1.69 (42.9)	0.38 (9.7)
1	SS-MBU-MF16	3.50 (88.9)	0.74 (18.7)	0.56 (14.3)	1.38 (34.9)	2.13 (54.0)	1.94 (49.3)	0.38 (9.7)

**Union Elbows**

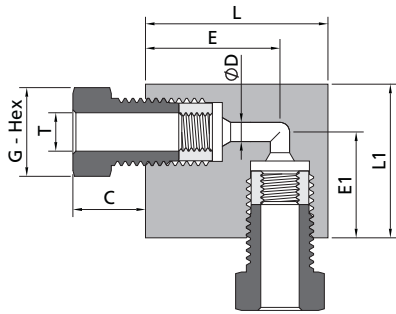

Tube		Dimensions, in. (mm)							
T - Tube O.D. in.	Ordering Number	C	D	G	L	E	L1	E1	Thickness
1/4	SS-MLU-MF4	0.38 (9.7)	0.11 (2.8)	0.50 (12.7)	1.12 (28.4)	0.75 (19.1)	1.12 (28.4)	0.75 (19.1)	0.63 (15.9)
3/8	SS-MLU-MF6	0.44 (11.2)	0.20 (5.1)	0.63 (15.9)	1.38 (34.9)	1.00 (25.4)	1.38 (34.9)	1.00 (25.4)	0.75 (19.1)
9/16	SS-MLU-MF9	0.55 (14.0)	0.31 (7.9)	0.94 (23.8)	1.75 (44.5)	1.25 (31.8)	1.75 (44.5)	1.25 (31.8)	1.00 (25.4)
3/4	SS-MLU-MF12	0.60 (15.2)	0.44 (11.1)	1.19 (30.2)	2.25 (57.2)	1.50 (38.1)	2.25 (57.2)	1.50 (38.1)	1.38 (34.9)
1	SS-MLU-MF16	0.74 (18.7)	0.56 (14.3)	1.38 (34.9)	3.00 (76.2)	2.06 (52.3)	3.00 (76.2)	2.06 (52.3)	1.75 (44.5)

Fittings
Tubing
Quick Couplings
Line Filters
Valves
Sour Service Products
Subsea Valves
Tools and Installation Instructions
Technical Information
Part Number Crossover Charts

Union Tees

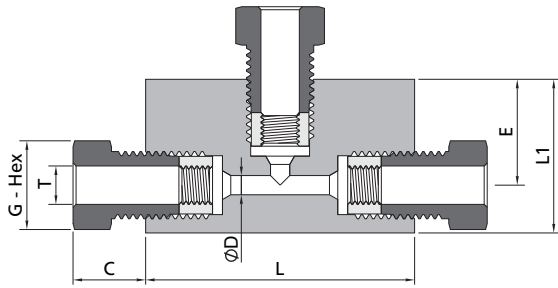

Tube		Dimensions, in. (mm)						
T - Tube O.D. in.	Ordering Number	C	D	G	L	L1	E	Thickness
1/4	SS-MT-MF4	0.38 (9.7)	0.11 (2.8)	0.50 (12.7)	1.50 (38.1)	1.12 (28.4)	0.75 (19.1)	0.63 (15.9)
3/8	SS-MT-MF6	0.44 (11.2)	0.20 (5.1)	0.63 (15.9)	2.00 (50.8)	1.38 (34.9)	1.00 (25.4)	0.75 (19.1)
9/16	SS-MT-MF9	0.55 (14.0)	0.31 (7.9)	0.94 (23.8)	2.50 (63.5)	1.75 (44.5)	1.25 (31.8)	1.00 (25.4)
3/4	SS-MT-MF12	0.60 (15.2)	0.44 (11.1)	1.19 (30.2)	3.00 (76.2)	2.25 (57.2)	1.50 (38.1)	1.38 (34.9)
1	SS-MT-MF16	0.74 (18.7)	0.56 (14.3)	1.38 (34.9)	4.12 (104.6)	3.00 (76.2)	2.06 (52.3)	1.75 (44.5)

Union Crosses

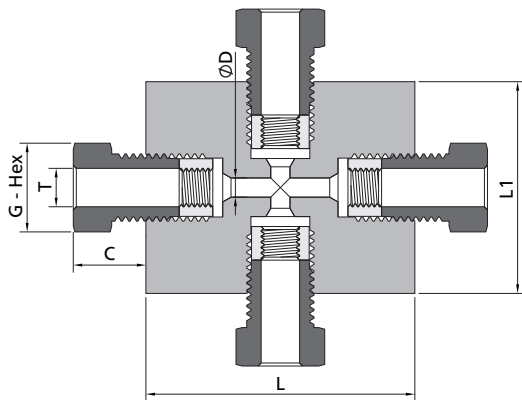

Tube		Dimensions, in. (mm)					
T - Tube O.D. in.	Ordering Number	C	D	G	L	L1	Thickness
1/4	SS-MX-MF4	0.38 (9.7)	0.11 (2.8)	0.50 (12.7)	1.50 (38.1)	1.50 (38.1)	0.63 (15.9)
3/8	SS-MX-MF6	0.44 (11.2)	0.20 (5.1)	0.63 (15.9)	2.00 (50.8)	2.00 (50.8)	0.75 (19.1)
9/16	SS-MX-MF9	0.55 (14.0)	0.31 (7.9)	0.94 (23.8)	2.50 (63.5)	2.50 (63.5)	1.00 (25.4)
3/4	SS-MX-MF12	0.60 (15.2)	0.44 (11.1)	1.19 (30.2)	3.00 (76.2)	3.00 (76.2)	1.38 (34.9)
1	SS-MX-MF16	0.74 (18.7)	0.56 (14.3)	1.38 (34.9)	4.12 (104.6)	4.12 (104.6)	1.75 (44.5)

### Anti-vibration Gland Assemblies

Working pressure: 20,000 psig (1379 bar)

Tubing systems may be subject to extreme vibration or shock. In such applications, these assemblies provide the same reliable connection as standard FITOK glands to essentially prolong vibrational fatigue life.

A complete ordering number for anti-vibration gland assembly (for example: SS-MAV-MF4) includes gland nut, slotted collet and collet body. These three parts can also be ordered separately, as shown in the tables below. To order components with anti-vibration gland assemblies, add "-AV" to ordering number.

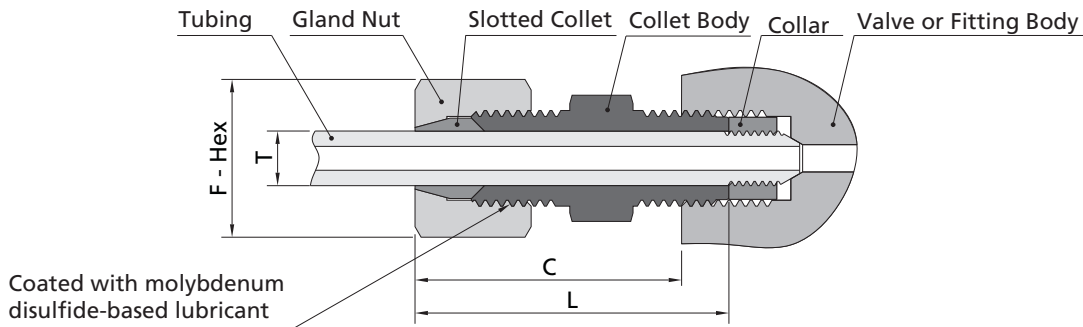

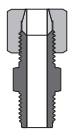
Tube					
Anti-vibration Gland Assemblies	T - Tube O.D. in.	Ordering Number	Dimensions, in. (mm)		
			L	C	F
	1/4	SS-MAV-MF4	1.24 (31.6)	1.05 (26.7)	0.63 (15.9)
	3/8	SS-MAV-MF6	1.50 (38.1)	1.22 (30.9)	0.81 (20.6)
	9/16	SS-MAV-MF9	1.78 (45.2)	1.42 (36.0)	0.94 (23.8)
	3/4	SS-MAV-MF12	2.00 (50.8)	1.61 (40.8)	1.38 (34.9)
	1	SS-MAV-MF16	2.38 (60.5)	1.74 (44.3)	1.50 (38.1)

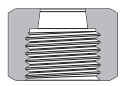
Tube		
Gland Nut	T - Tube O.D. in.	Ordering Number
	1/4	SS-MAV-MF4-N
	3/8	SS-MAV-MF6-N
	9/16	SS-MAV-MF9-N
	3/4	SS-MAV-MF12-N
	1	SS-MAV-MF16-N

Tube		
Slotted Collet	T - Tube O.D. in.	Ordering Number
	1/4	SS-MAV-MF4-SC
	3/8	SS-MAV-MF6-SC
	9/16	SS-MAV-MF9-SC
	3/4	SS-MAV-MF12-SC
	1	SS-MAV-MF16-SC

Tube		
Collet Body	T - Tube O.D. in.	Ordering Number
	1/4	SS-MAV-MF4-B
	3/8	SS-MAV-MF6-B
	9/16	SS-MAV-MF9-B
	3/4	SS-MAV-MF12-B
	1	SS-MAV-MF16-B

Fittings
Tubing
Quick Couplings
Line Filters
Valves
Sour Service Products
Subsea Valves
Tools and Installation Instructions
Technical Information
Part Number Crossover Charts



## Installation Instructions

Please see H-07.

## Connection Information

Please see I-02.

## Ordering Number Description

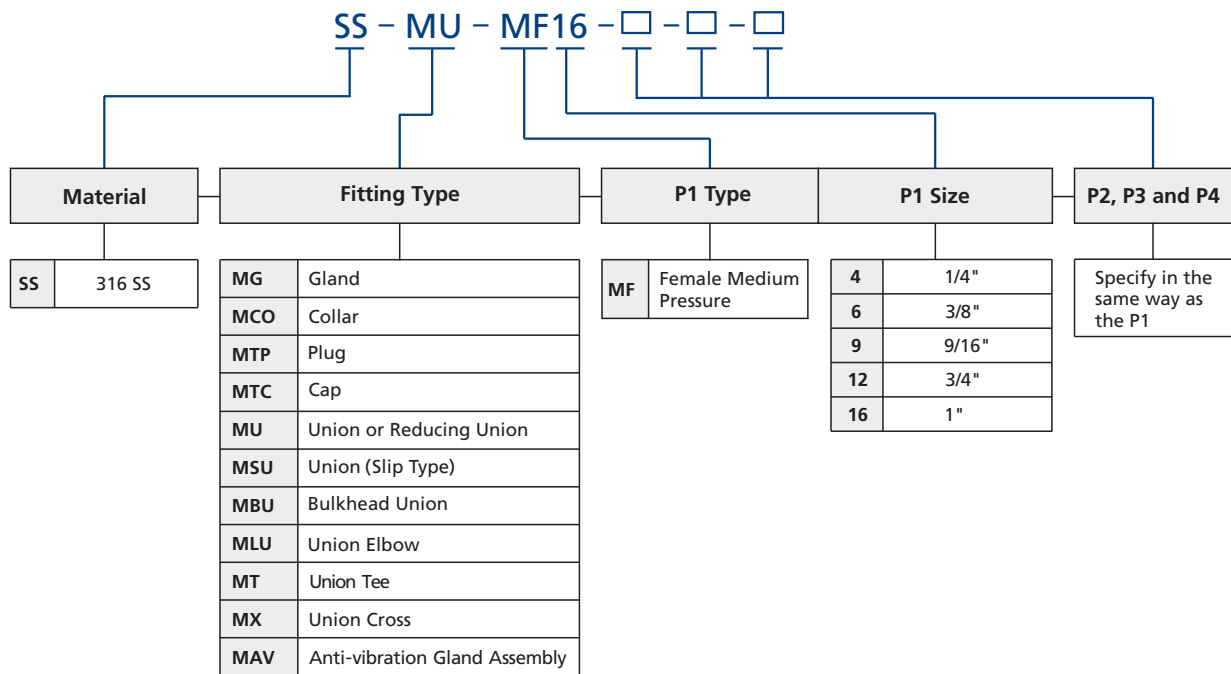

- NOTES: 1. For more details regarding Medium Pressure connection, please see **Connection Information** on I-02.
2. "Ordering Number Description" is a reference to understand the combination rules of FITOK product part number. Not all combinations are available.

Fittings
Tubing
Quick Couplings
Line Filters
Valves
Sour Service Products
Subsea Valves
Tools and Installation Instructions
Technical Information
Part Number Crossover Charts